

Macurco™ Control Panel DVP-120

MACURCO
GAS DETECTION



Detection, Ventilation and Control

Detection and Ventilation Control Panel

The DVP-120 exhaust fan controller, in conjunction with Macurco™ gas transducers, provides automatic controls to help maintain an acceptable environment in parking garages or other facilities. The DVP-120 system is designed to meet specifications for safety in enclosed parking garages, including the Uniform Building Code and OSHA 50ppm CO requirements. The DVP-120 can control up to twelve gas sensors in any combination.

Features

- External keypad for user selection of the transducer/alarm display and setting the configuration
- Externally visible LCD display showing the status of each transducer and relay
- Externally visible system, alarm and relay status indicators
- Compatible with all Macurco™ 6-Series gas sensors
- Twelve analog (current loop) input channels
- Three 10A, 240 VAC SPDT fan/alarm relays
- Drivers for external Horn and Strobe
- Fail safe operation can be implemented
- Lockable NEMA 1 type enclosure
- Modular input and output connectors
- ETL Listed to UL 508A, CAN/CSA-C22.2 No. 14-13, LADBS Approved
- Up to three ventilation control zones can be defined
- Each zone can be controlled based on transducer signals and/or time of day
- Each relay is configurable for delay before activation and minimum on time



DVP-120 Specifications

- Power Input: 90 – 250 VAC, 1 Amp, 47 – 63 Hz, single phase
- Size: 10.5" x 12.5" x 2." (267 mm x 318 mm x 51 mm)
- Weight: 6 ½ lb (2.9 kg)
- Enclosure: NEMA 1 Type
- Operating Temperature: 32 to 104°F (0° to 40°C)
- Operating Humidity: 0% to 95% RH non-condensing
- Relay Rating (3): SPDT, 120/240 VAC, 10 A resistive
- LCD Display: 2 rows of 16 characters with backlight
- Audible indicator: Internal buzzer, 90 dBA at 1ft
- External Drivers (2): 24VDC, maximum 250 mA
- Relay On Delay: 0 – 15 minutes in 1 second increments
- Relay Off Delay: 0 – 15 minutes in 1 second increments
- Status Indicators (LED): Power, ALARM/warning, Hush, Relay 1, Relay 2 & Relay 3



Installation & Connection

Gas detection and exhaust fan control is provided by a Macurco™ DVP-120 system. System wiring includes the main power connection for the DVP-120, 4-20mA current loop and 24VDC power connections between the remote sensors and the DVP-120, the fan control connections and alarm connections from the DVP-120 to the building ventilation and automation systems. All power and signal connections for the sensors are provided from the DVP-120 control panel, via unshielded four conductor cable. The DVP-120 control panel provides three relays which can be used for ventilation fan control or alarm signaling. The ventilation control function operates independently from the alarm function. It provides the ability to configure the DVP-120 for control of one to three zones. Each zone can respond to gas levels at one or more of the sensors, with configurable rising and falling concentrations for each gas type. Each zone can also be controlled based on the time of day.

TYPICAL CONNECTION OF THE DVP-120 CONTROL PANEL

COVERAGE UP TO 60,000 SQAURE FEET

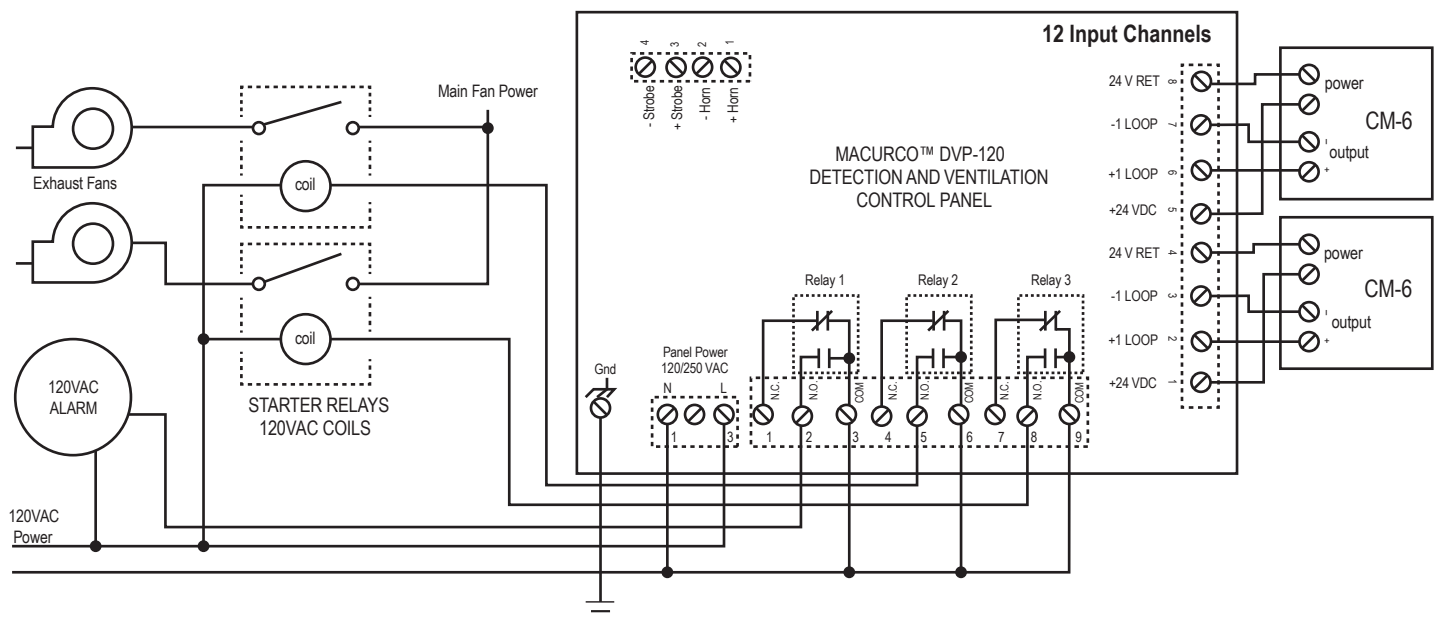

Made in the U.S.A. with US and imported materials

© Aerionics 2015. All rights reserved.
Macurco is a trademark of Aerionics, Inc.

